

SHINPO®

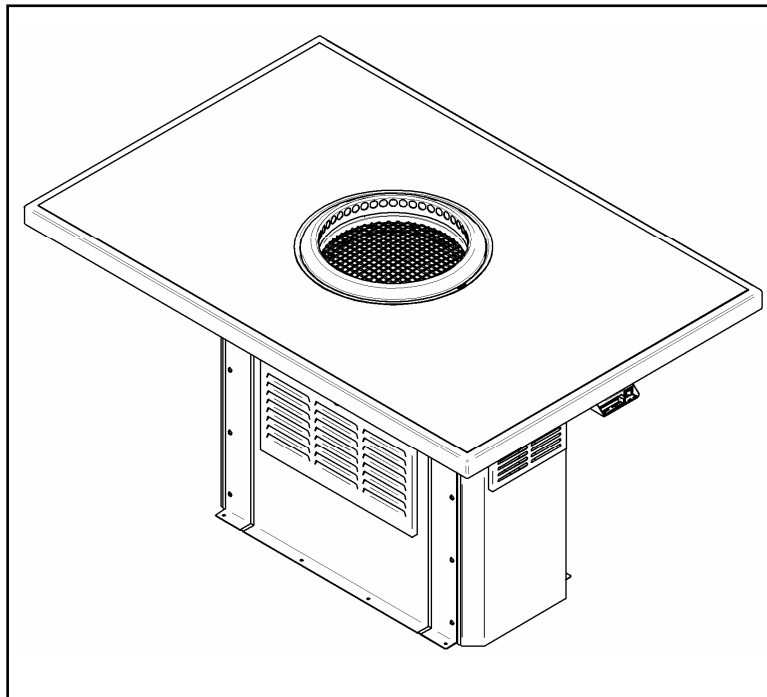

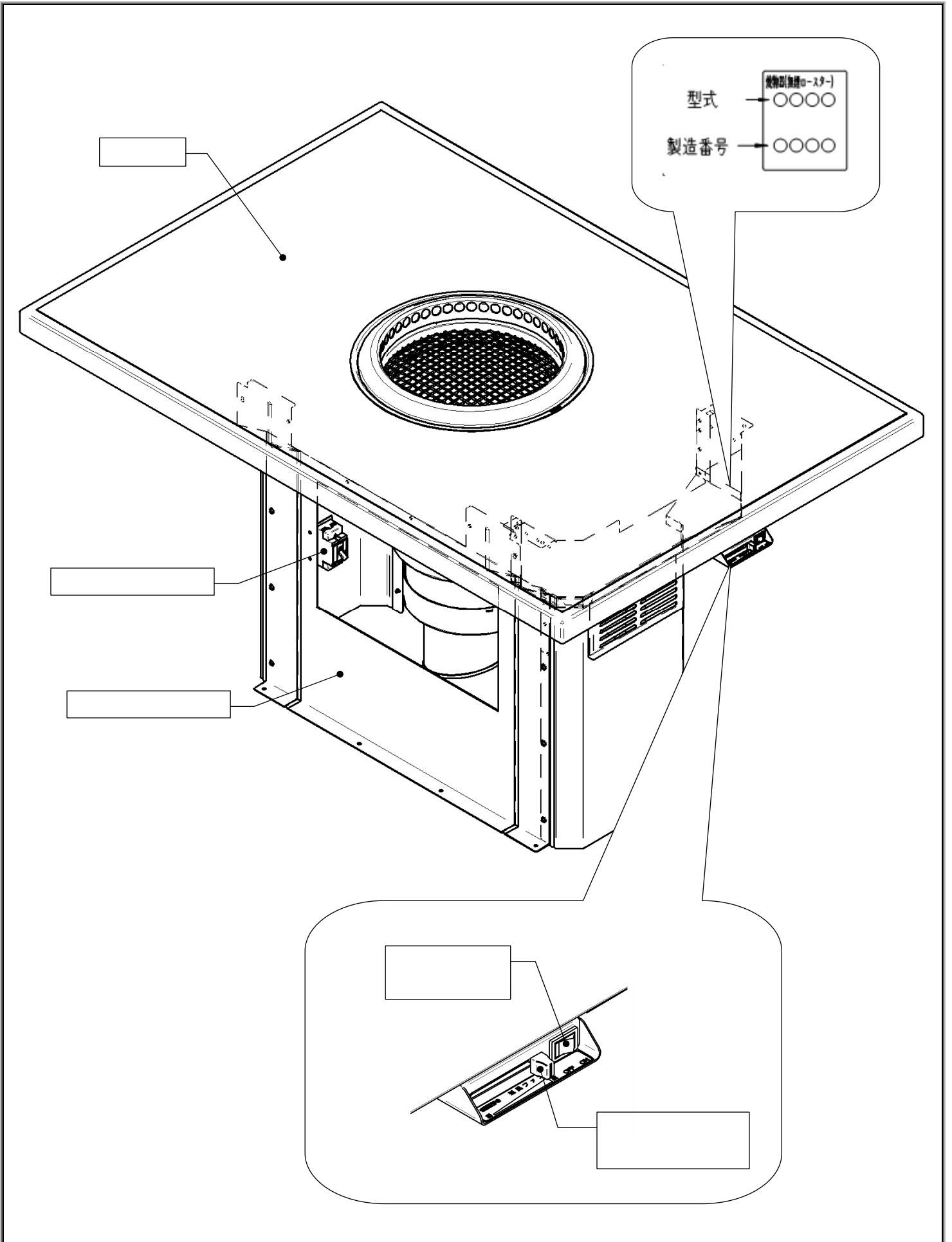



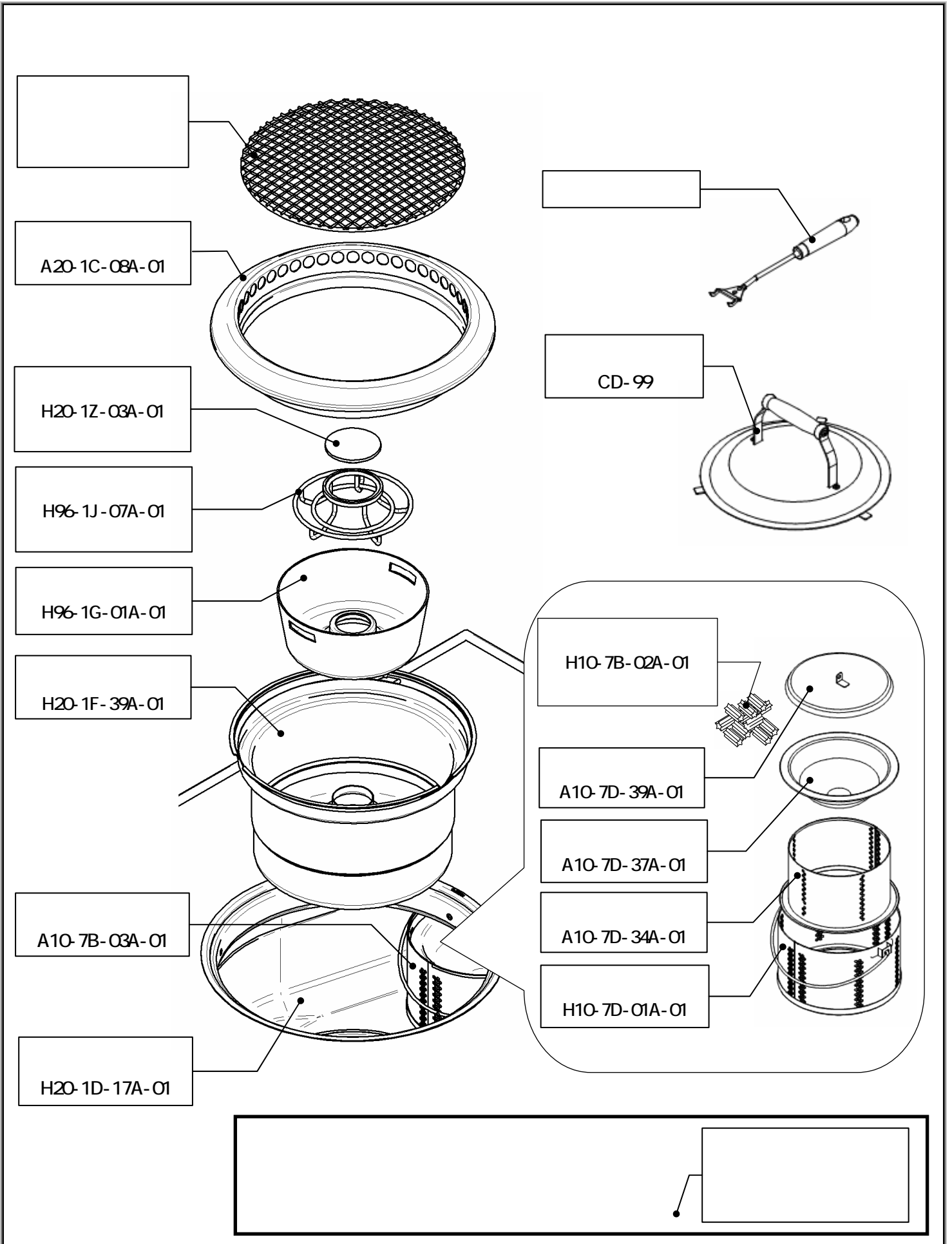

10
11
12
13
14

MEMO







	
	
	



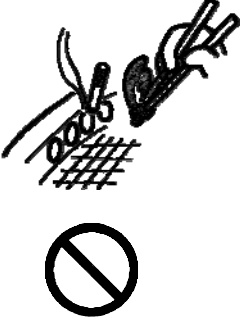

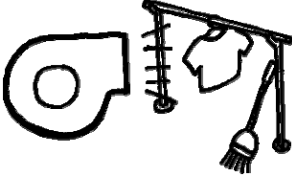

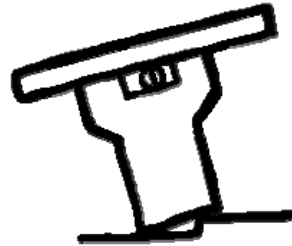
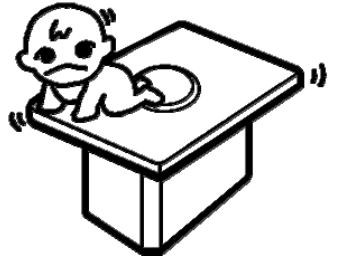

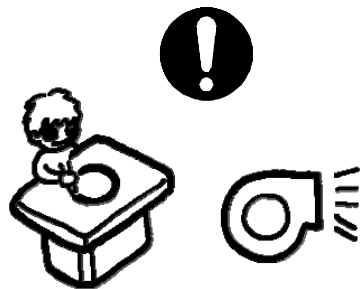
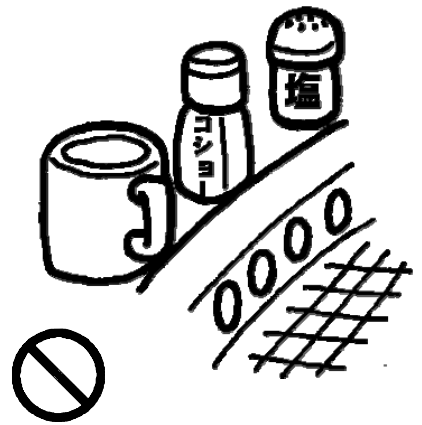
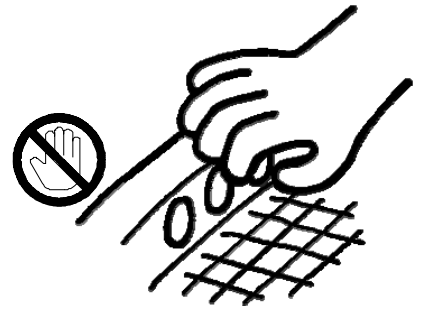
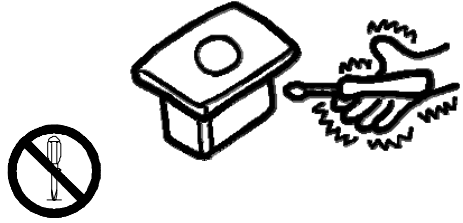
(1,2)

1.

2.

3.

4.

5.

6.

7.

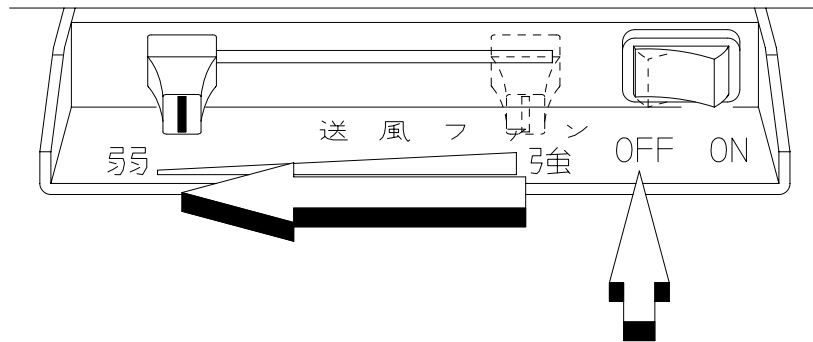
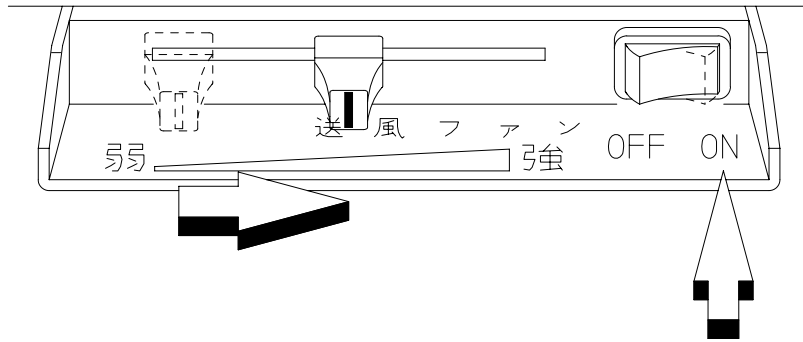
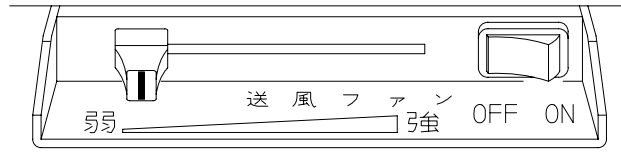

⚠	
⚠	
⚠	

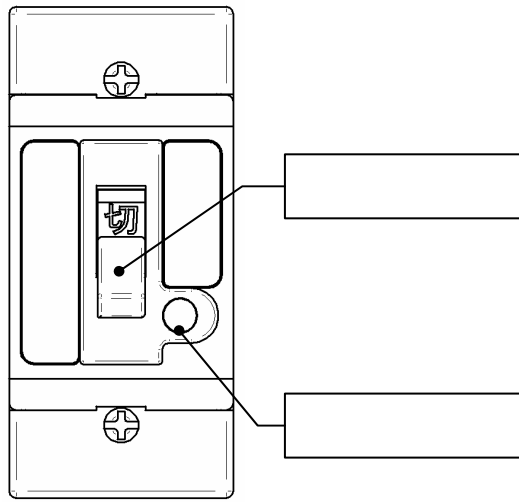

1 1

1 1

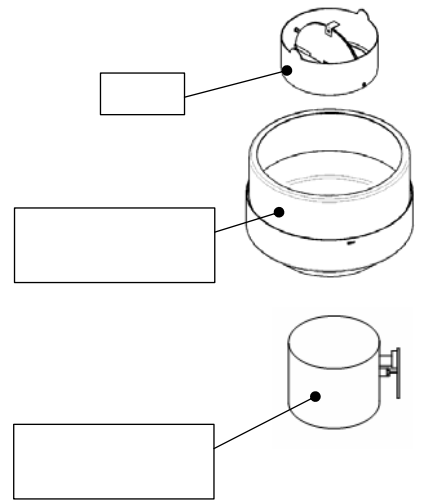

()

《單位：mm》

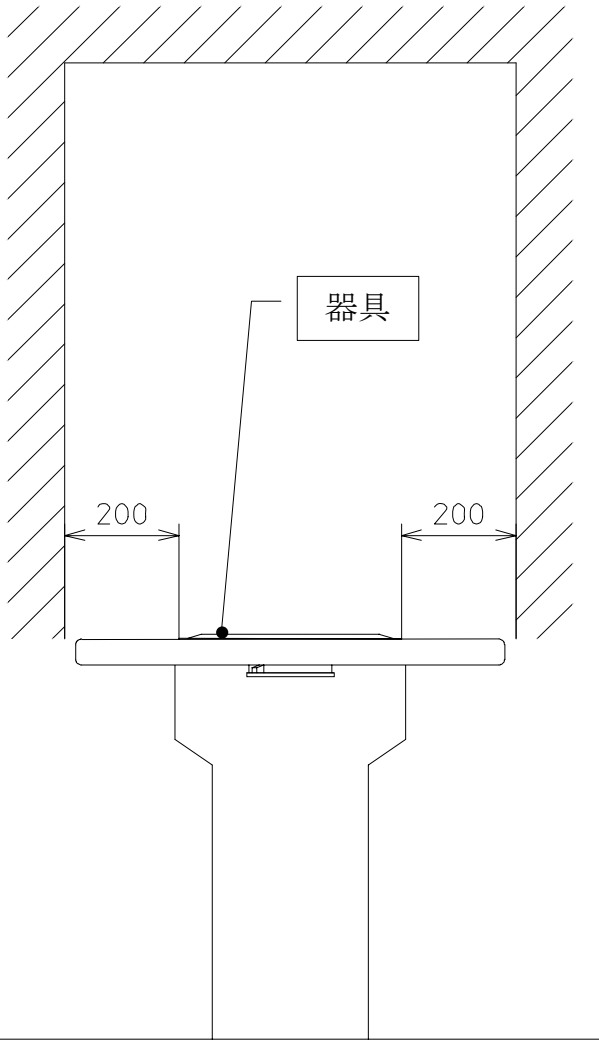

前 面

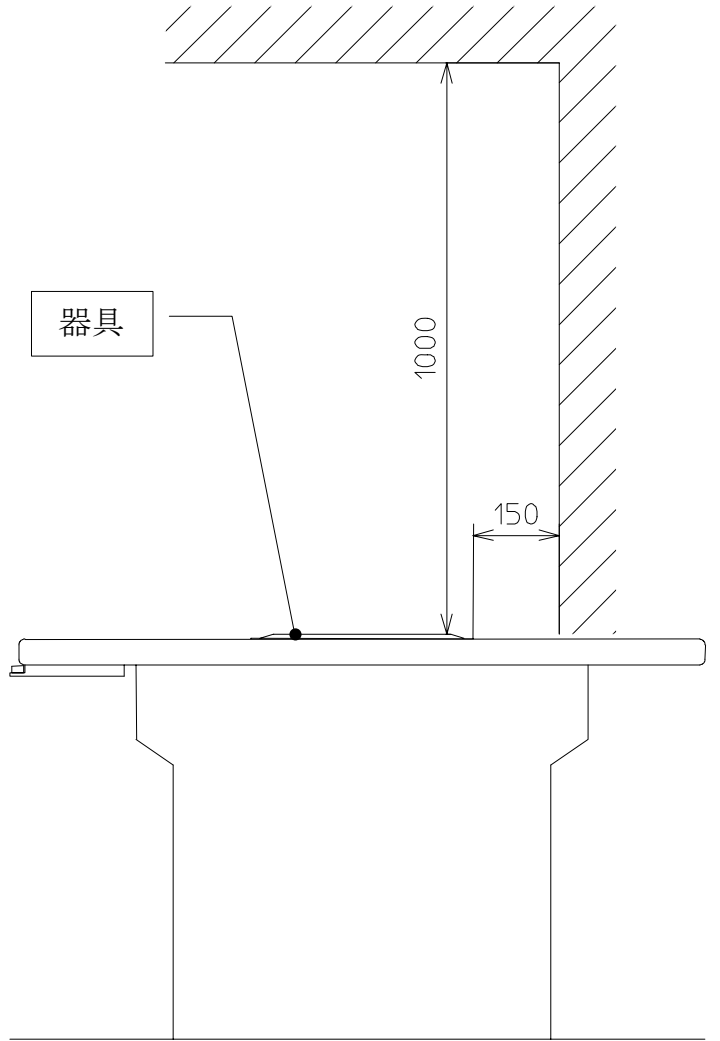

側 面

() 7

- (1)
- (2) ()
- (3)
- (4)

無煙ロースターータルシステムプロダクツ



TEL - -

FAX - -

TEL - -

FAX - -

TEL - -

FAX - -

TEL - -

FAX - -

TEL - -

FAX - -

TEL - -

FAX - -

TEL - -

FAX - -

TEL - -

FAX - -

TEL - -

FAX - -

